

Preparation work for TAMA SAS removal

2015-11-09

revised on 2015-11-11

APC, Paris Eleonora Capocasa

NAOJ Daisuke TATSUMI

Our goal is to install vibration isolation system for filter cavity experiment at TAMA. Before the installation, we should remove current TAMA SAS system from NM2 vacuum tank.

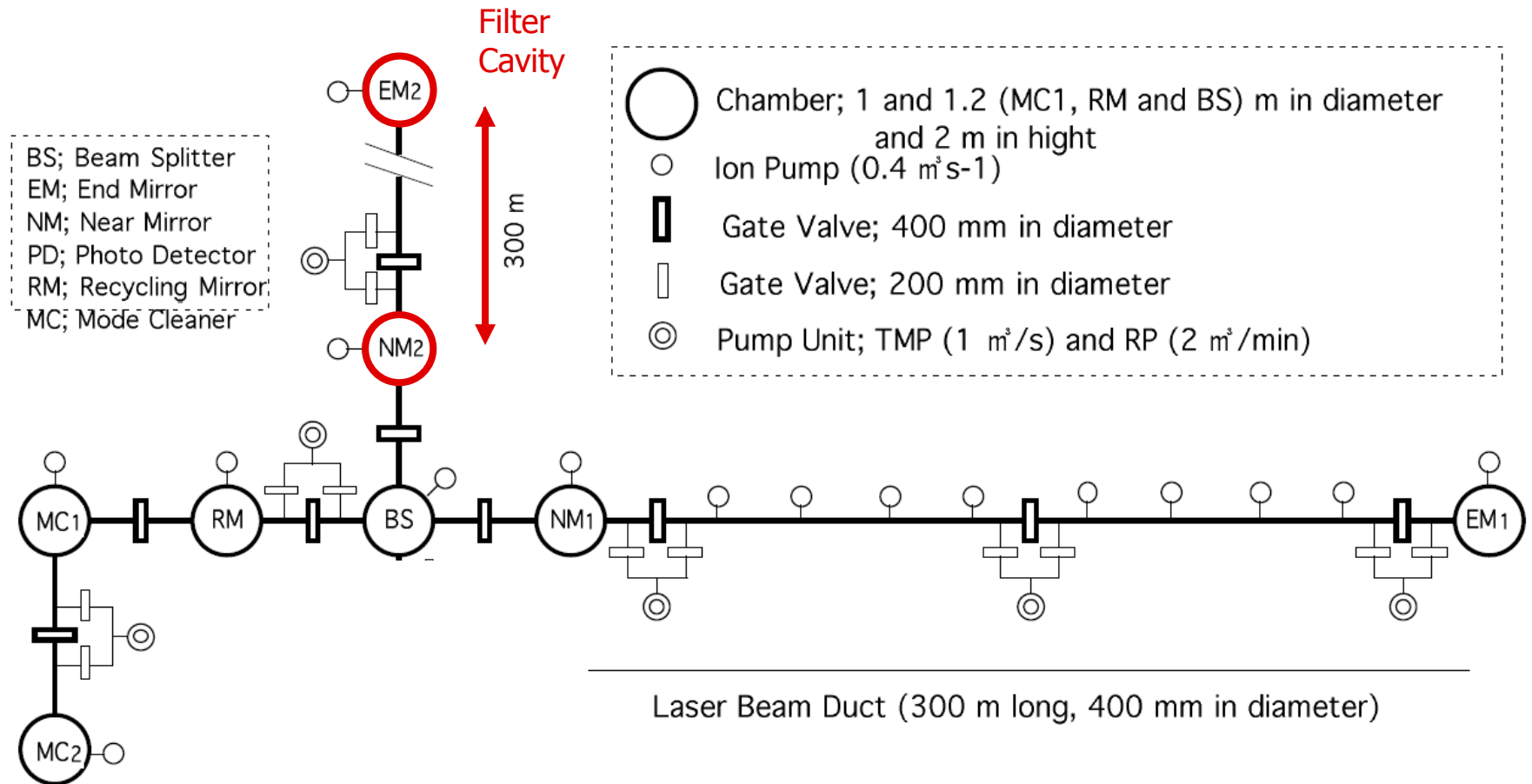

TAMA Vacuum System

TAMA SAS system

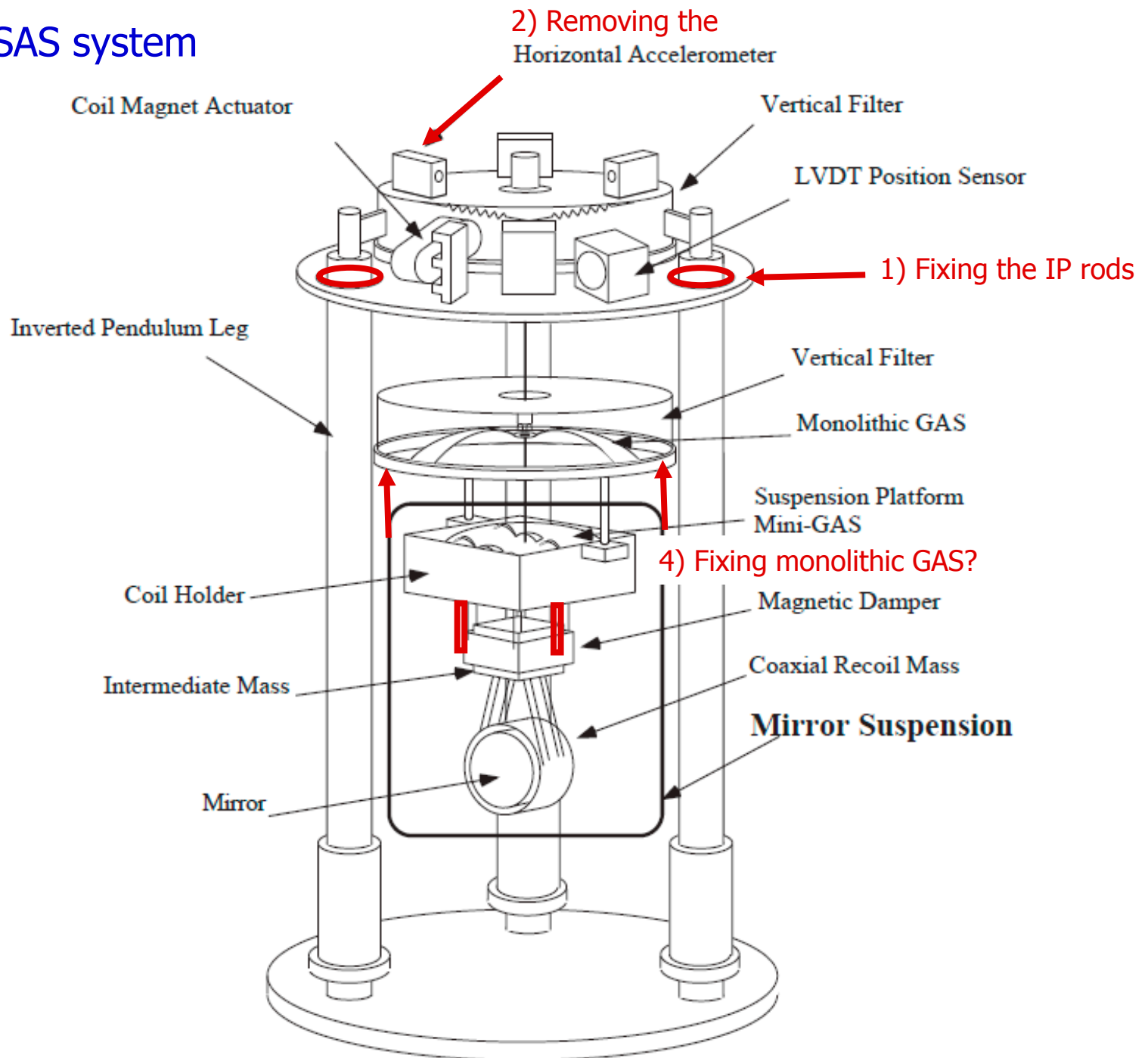

Before the removal, we should fix the suspension systems.

On 2015-11-09, the following things were done at NM2 tank.

- 1) Fixing the inverted pendulum to the top plate,
- 2) Removing three accelerometer units from the top plate,
- 3) Removing all of balance weights,
- 4) Fixing a monolithic GAS with two screws (among three pillars),
- 5) Fixing the suspension platform respect to the outer frame.
The outer-frame is fixed to the monolithic GAS. (we confirmed it)
- 6) Fixing the intermediate masses to the suspension platform.

Test mass mirror and its recoil mass were already removed by Takahashi-san.

Underlined works were done on 11 November, 2015.

1) Fixing the inverted pendulum to the top plate,

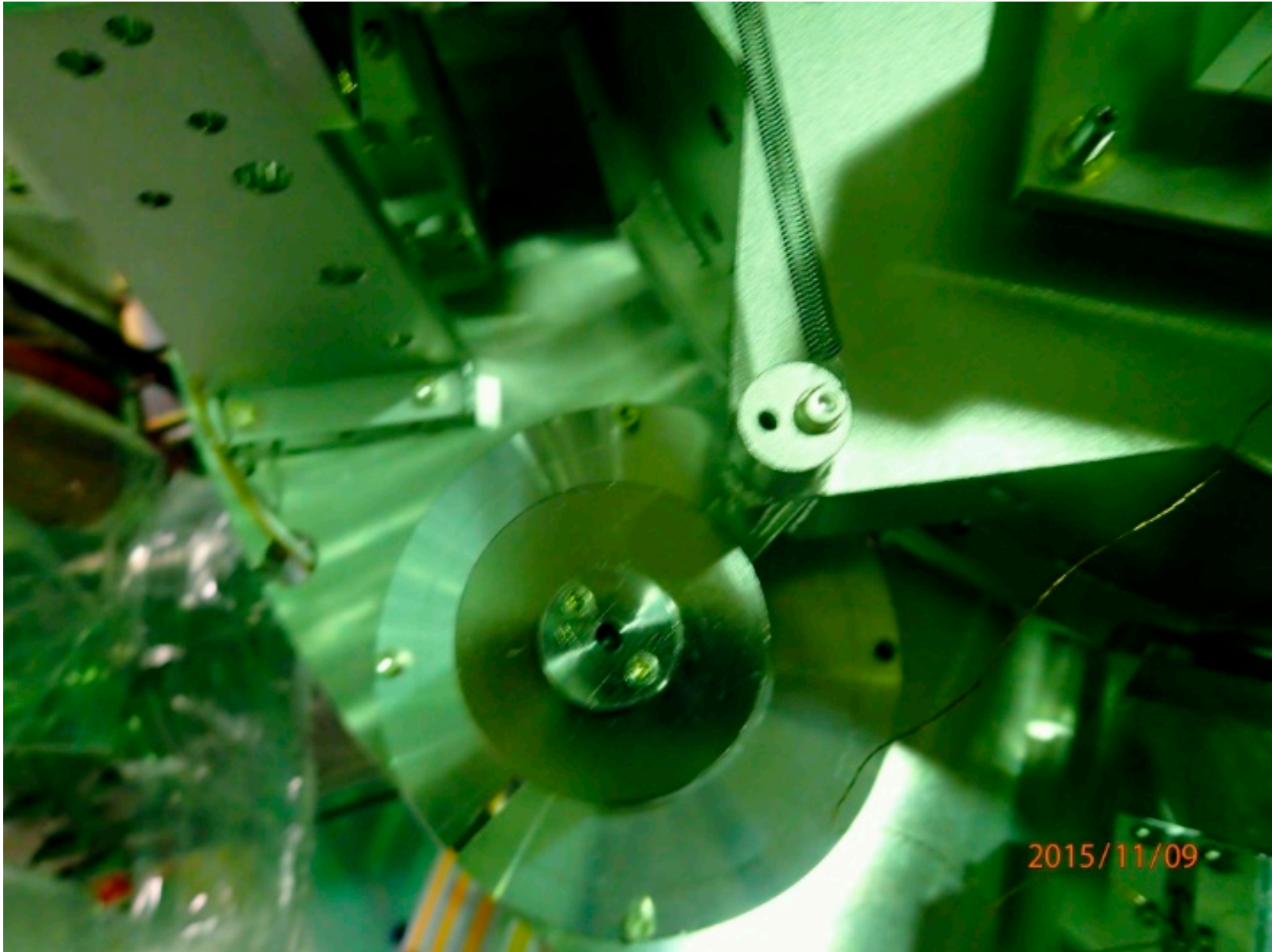

2) Removing three accelerometer units from the top plate

Because only one set-screw can be found, we do not use it.
Just fixing by side plates with screws.

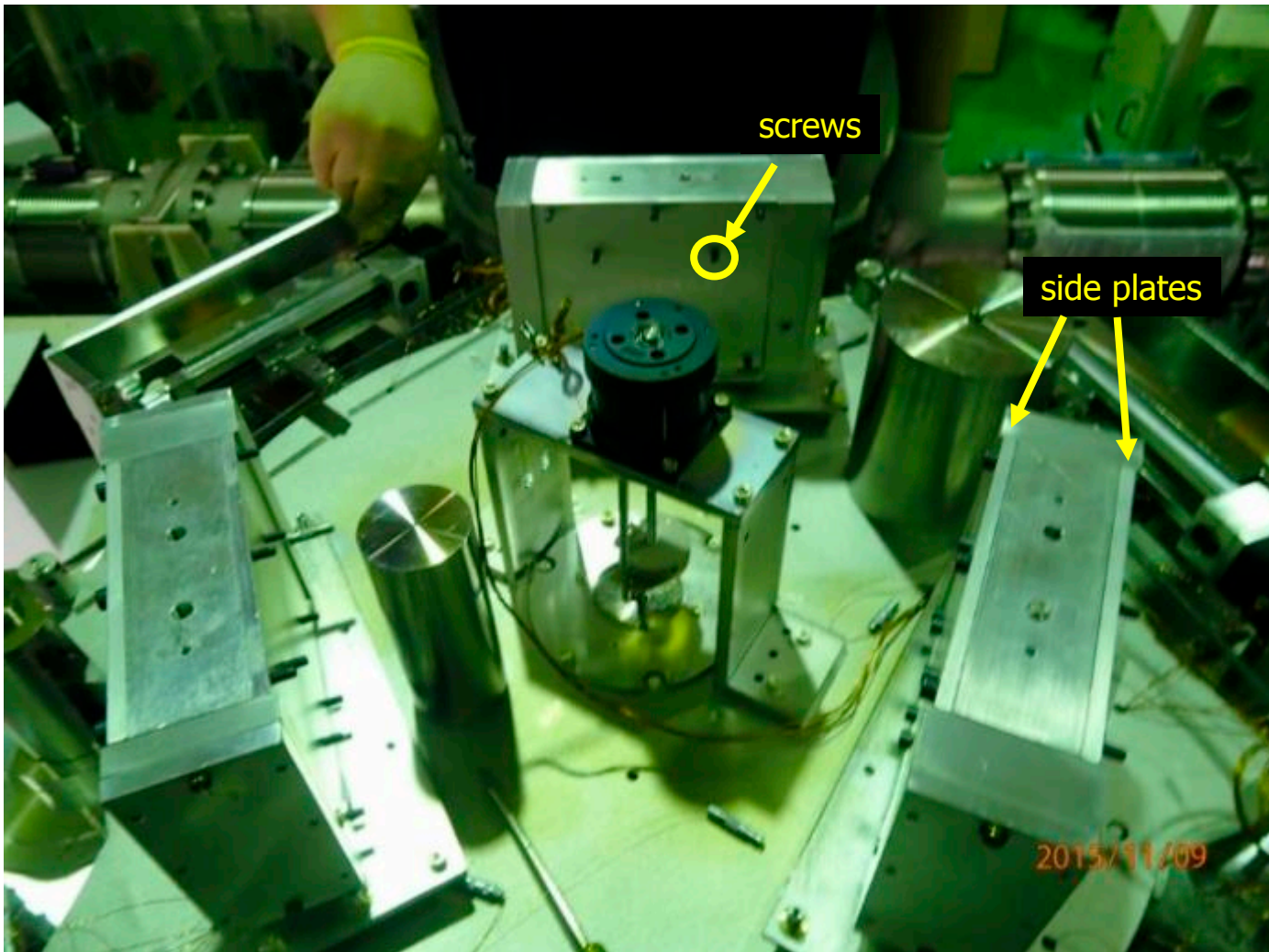

4) Fixing a monolithic GAS with two screws (among three),

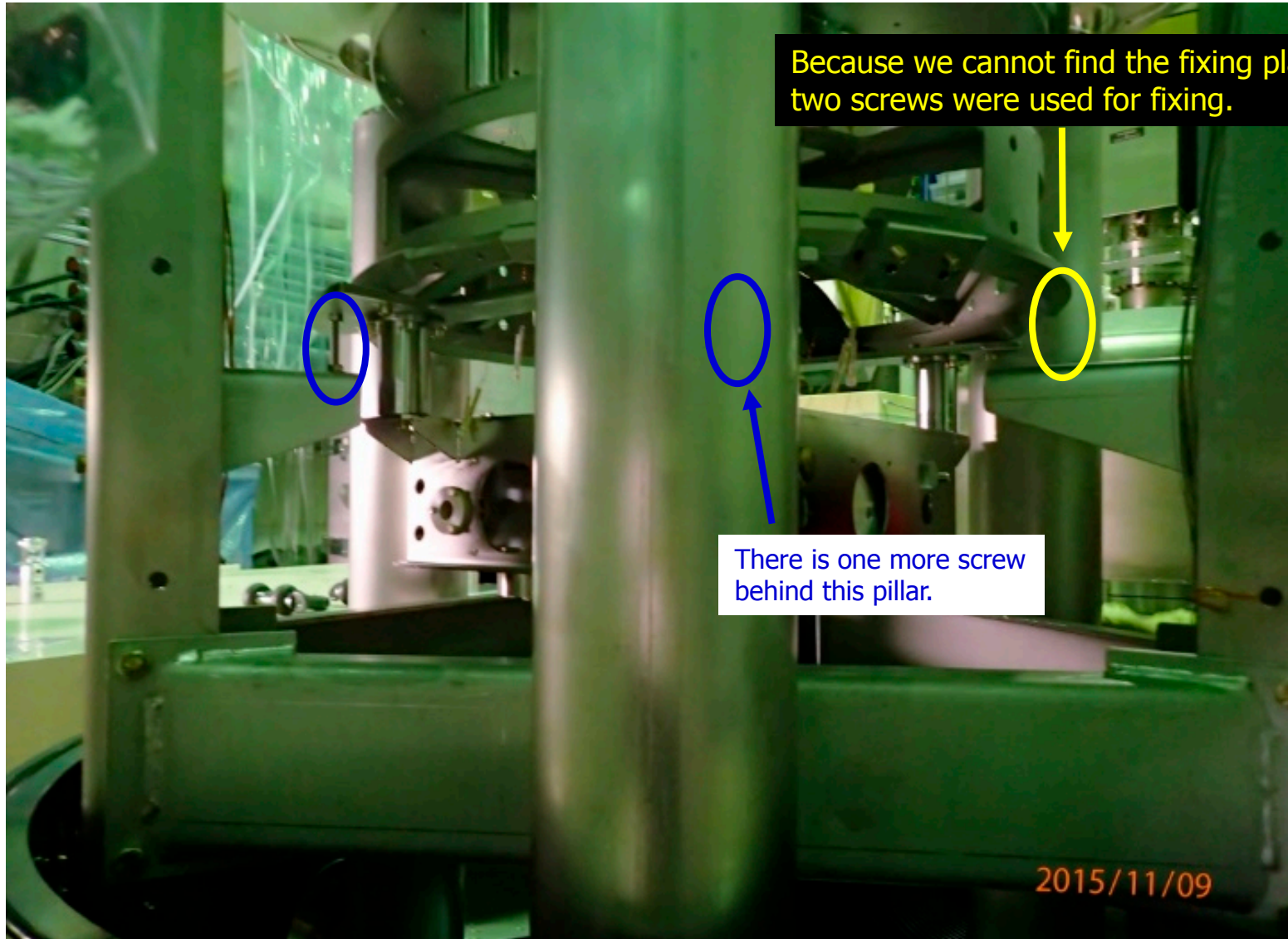

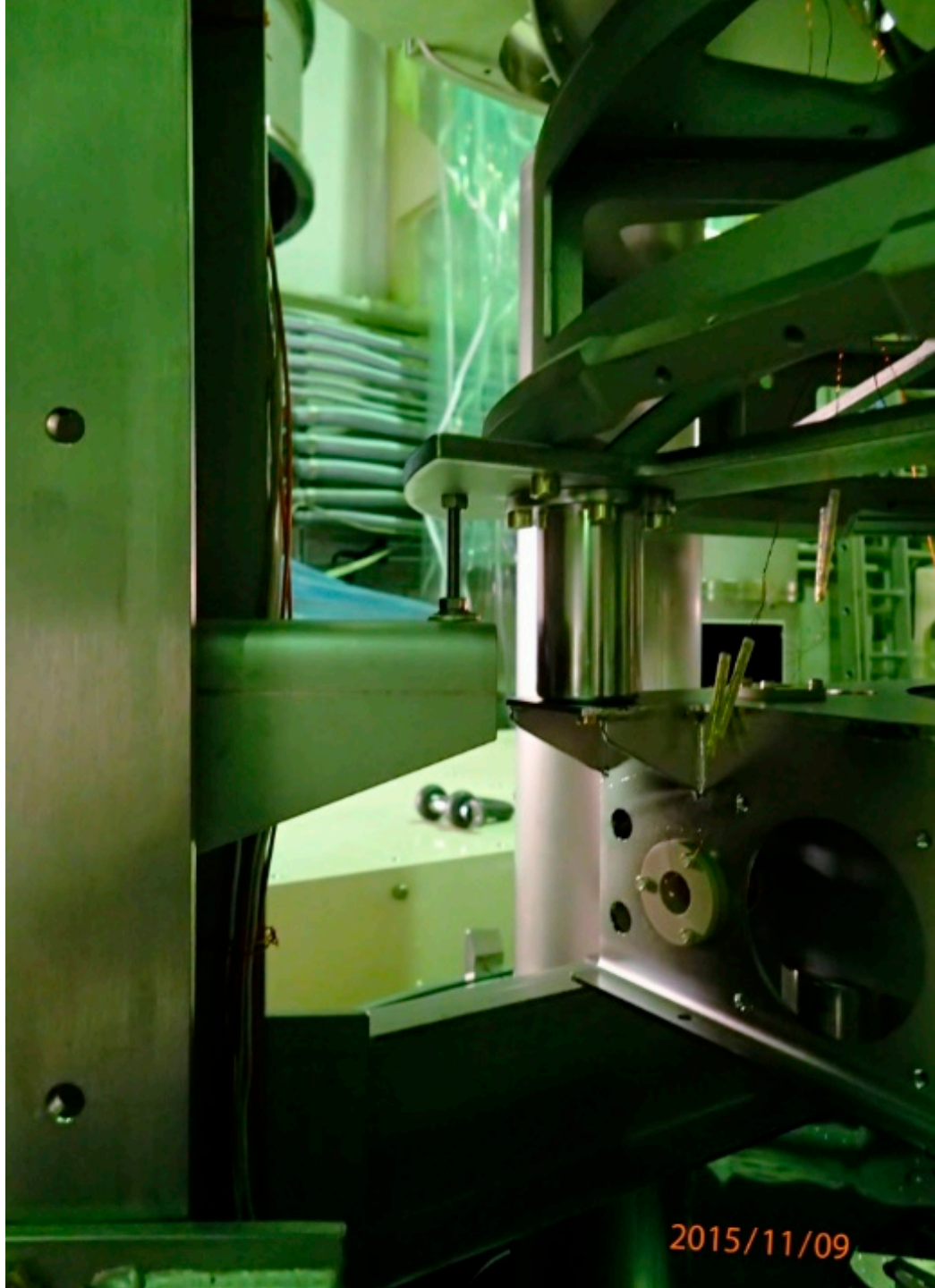

2015/11/09

6) Fixing the intermediate masses to the suspension platform.



7) Unplugging electrical cables

There is three feed-through flanges.

Among the three only one port is easy to access.

We gave up to unplug the other ports.

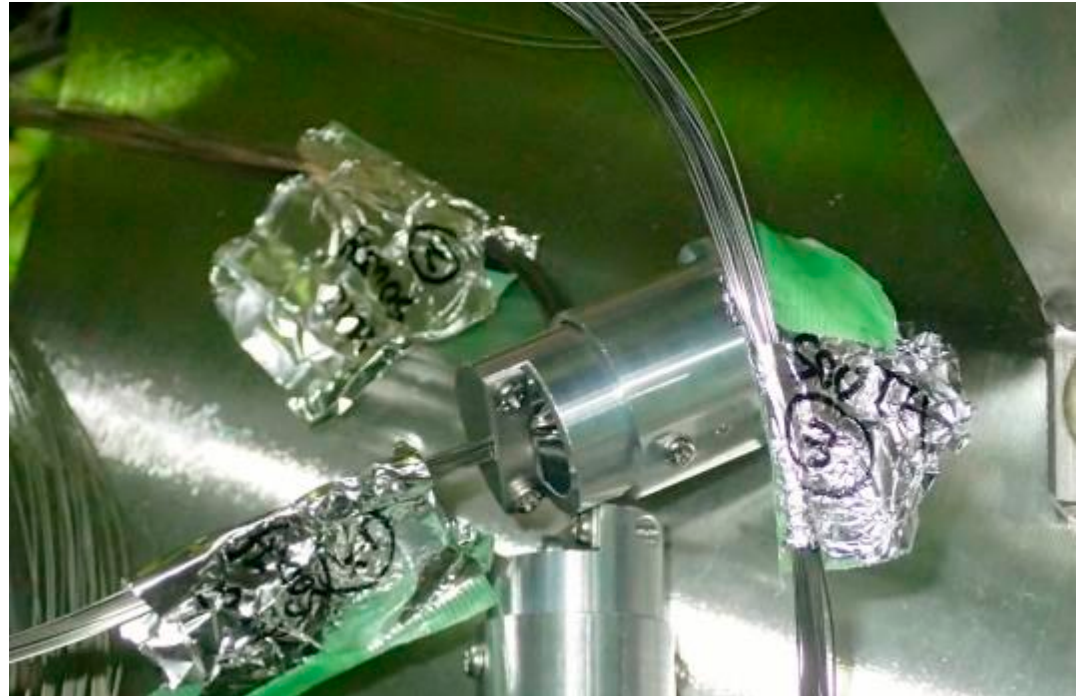

This port is very hard to access the connectors.
Therefore, we will try to access the port after hanging the TAMA SAS system.



8) Unscrewing TAMA SAS from the bottom of vacuum tank.

As you can see these screws are not fixed tightly.
Before jamming the screws TAMA people stopped to tighten.
Each two screws are completely tightened.

